

**F Series** FxxxxD-xW 3KVDC Isolation 0.1W~2W Unregulated single output DIP14 PIN**Input Volt.****3.3, 5, 9, 12, 15, 24 VDC****Output Volt.****3.3, 5, 9, 12, 15, 24 VDC**

Other specifications required, please inquire us for details.

**Technical Parameters**

All the parameters below are tested at TA=25° C, nominal input voltage, rated output current.

Input Parameters

Volt. Range	+/- 10 %
Filter	Ceramic-capacitor

Isolation Parameters

Rated Isolation Volt.	3000 VDC
Leak current	<1 m A
Resistance	10 ⁹ Ohm
Capacitor	60 pF TYP.

Output Parameters

Volt. Precision	+/- 5 %, max.
(20 MHz BW) Ripple&Noise	150mV p-p, max.
Continuous short-circuit time	Immediately (<1s)
Linear volt. Calibration	+/- 1,2 % / 1,0 % of Vin
Load volt. Calibration	+/- 8 %, load = 20 ~ 100 %
Temperature index	+/- 0,02 % / °C

General Parameters

Efficiency	55% to 85 %
Switching Frequency	60~125 KHz, type.

Environmental Parameters

Operating Temp. (environmental)	- 40° C to + 85° C
Storage Temp.	- 55 °C to + 125 °C
Reducing rated value	See temperature derating graph below
Humidity	≤ 90 %, Non-compression
Colling method	Natural Free-air

Dimension

DIP Package size	12.7 x 10.0 x 7.7 mm
	0.5 x 0.39 x 0.3 inch
	2.5 g~3.5 g

Weight**External Package Material**

Non-conductive flame-retardant black plastics

Typical Product List: (The parameters below are collected at 8 hours full-load aging test.)

Model No.	Input Volt. Vin(VDC)	Input Current Empty load (mA)	Input Current Full load (mA)	Output Volt. Vout(VDC)	Output Current (max.mA)	Efficiency Full load (%TYPE)
F0503D-W1	5	5	34	3.3	30	59
F0505D-W1	5	4	33	5	20	60
F0512D-W1	5	8	32	12	8	60
F1205D-W1	12	5	14	5	20	61
F1212D-W1	12	5	14	12	8	60
F1215D-W1	12	5	13	15	7	62
F2405D-W1	24	5	7	5	20	60
F2412D-W1	24	5	7	12	8	61



F Series FxxxxD-xW 3KVDC Isolation 0.1W~2W Unregulated single output DIP14 PIN

Model No.	Input Volt. Vin(VDC)	Input Current Empty load (mA)	Input Current Full load (mA)	Output Volt. Vout(VDC)	Output Current (max.mA)	Efficiency Full load (%TYPE)
F0505D-W25	5	7	81	5	50	62
F1205D-W25	12	6	34	5	50	62
F1212D-W25	12	5	35	12	21	61
F1215D-W25	12	7	32	15	17	62
F2405D-W25	24	5	17	5	50	62
F2412D-W25	24	4	16	12	21	63
F2415D-W25	24	4	15	15	17	65
F0503D-W5	5	16	167	3.3	150	60
F0505D-W5	5	12	159	5	100	63
F0512D-W5	5	18	154	12	42	65
F1205D-W5	12	11	67	5	100	62
F1212D-W5	12	10	66	12	42	63
F1215D-W5	12	10	63	15	34	66
F2405D-W5	24	6	33	5	100	63
F2412D-W5	24	7	32	12	42	65
F2415D-W5	24	8	27	15	34	66
F0503D-W75	5	22	246	3.3	227	61
F0505D-W75	5	22	238	5	150	63
F0512D-W75	5	14	242	12	63	62
F0515D-W75	5	14	238	15	50	63
F1205D-W75	12	15	100	5	150	62
F1212D-W75	12	12	97	12	63	64
F1215D-W75	12	10	96	15	50	65
F1512D-W75	15	7	79	12	63	63
F1515D-W75	15	7	77	15	50	64
F0505D-1W	5	27	263	5	200	76
F0512D-1W	5	26	256	12	84	78
F0524D-1W	5	26	256	24	42	78
F1212D-1W	12	12	107	12	84	78
F1215D-1W	12	11	104	15	67	80
F2405D-1W	24	8	54	5	200	77
F2409D-1W	24	8	54	9	111	77
F2412D-1W	24	8	54	12	84	77
F2415D-1W	24	7	55	15	67	76
F0503D-2W	5	60	571	3.3	606	70
F0505D-2W	5	42	513	5	400	78
F0512D-2W	5	26	500	12	167	80
F1205D-2W	12	22	222	5	400	75
F1212D-2W	12	20	208	12	167	80
F1215D-2W	12	18	214	15	133	78
F2405D-2W	24	8	111	5	400	75
F2412D-2W	24	8	101	12	167	82
F2415D-2W	24	8	98	15	133	85



Functional Block Diagram:

Single Output

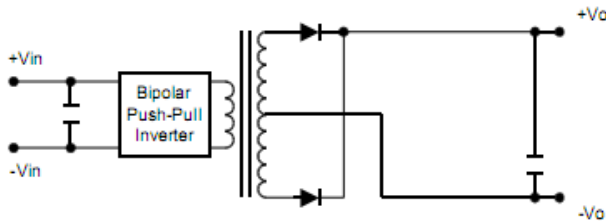

Dual Output

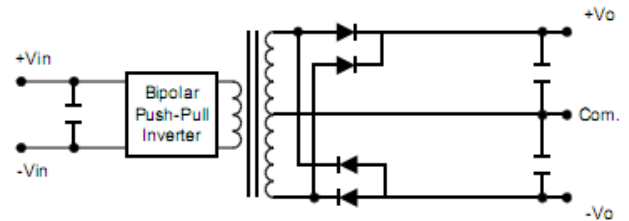

External Dimension & PCB Installation:

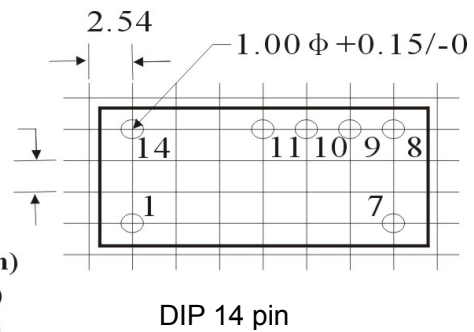
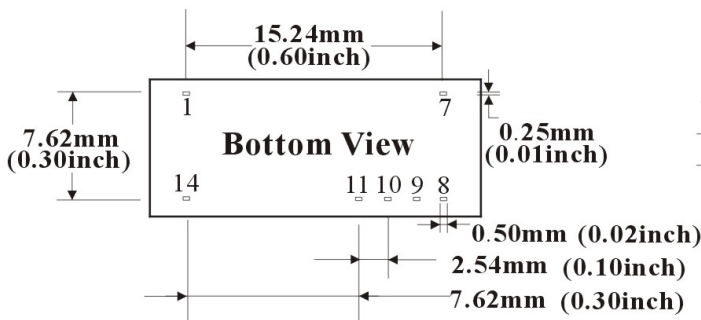
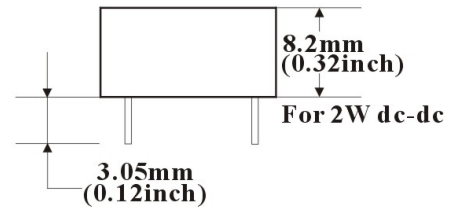
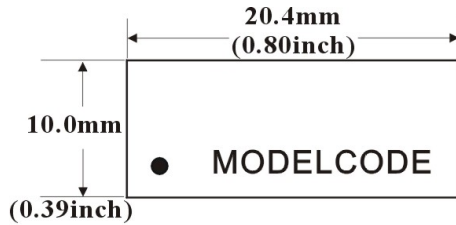

Temperature Derating Graph and PIN Definition

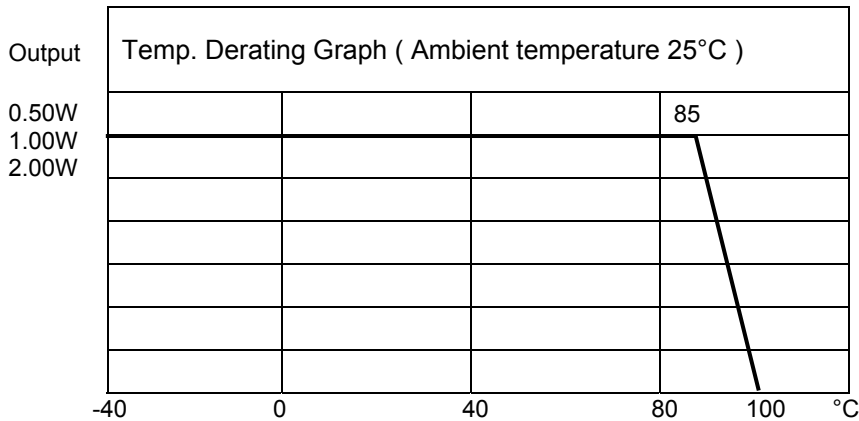

Pin	Function
14	+ Vin Input +
1	- Vin Input -
2~6	
7	NC
8	0 0V Common
9	+ Vout Output +
10	NC
11	- Vout Output -
12,13	

* Note: the product design and specification are subject to change without notice.